



CORBEILLE ACIER 55L ARENAS

CONCEPTION :



- Structure en fer plat 20x4mm
- Equipée d'un seau amovible de diam. 350mm et d'un socle
- Vidage par seau amovible
- Verrouillage par batteuse et clé carrée
- Visserie pour fixation sur le socle fourni
- A poser ou à sceller

DIMENSION et Poids :



- Diamètre extérieur : 590mm
- Diamètre de la cuve : 350mm
- Hauteur totale : 930mm
- Capacité : 55L
- Poids 28kgs

FINITION :



- Finition peinture au four Coloris Ral 3004 Rouge pourpre, Ral 5010 Bleu gentiane, Ral 6005 Vert mousse, Ral 7016 Gris anthracite, et Ral 9005 Noir

OPTIONS :



Montage et livraison :



Nous consulter
Le cout de transport dépend des quantités et du département de livraison.

RALS STANDARDS :



RAL 5010



RAL 9005



RAL 3004



RAL 7016

En image :

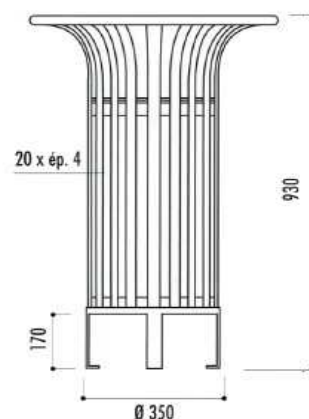
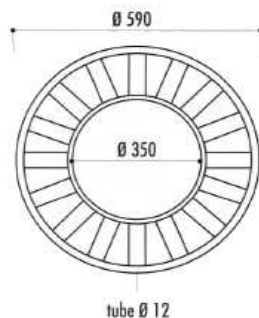

ETS PYRENEES-EQUIPEMENTS

Route de Mauléon

65370 Troubat

Tel : 05-62-39-25-51

Fax : 05-62-39-22-55