



CORBEILLE ACIER SANTIAGO 65L

CONCEPTION :



- Structure en acier galvanisé & peint Gris martelé
- Bac amovible en acier galvanisé
- Couvercle rabattable
- Serrure de fermeture - clé carrée
- Fixation par scellement

DIMENSION et Poids :



- Diam. 450 x H. Hors tout 800mm
- Capacité : 65L
- Poids 40kg



FINITION :



- Finition peint Gris martelé

OPTIONS :



Montage et livraison :



Nous consulter
Le cout de transport dépend des quantités et du département de livraison.

En image :

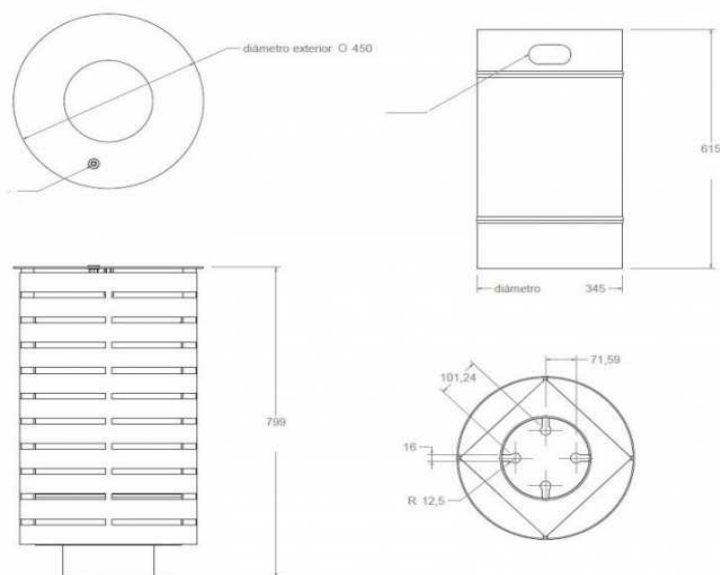

ETS PYRENEES-EQUIPEMENTS

Route de Mauléon

65370 Troubat

Tel : 05-62-39-25-51

Fax : 05-62-39-22-55